



Maintenance Kit Manual

Deep Well 1 ½" Pump Cylinder

Cylinder Revision Level: D



BISON PUMPS
The Power of Water in Your Hands

Table of Contents

Maintenance Kit Components	3
Before you begin	4
Required Tools	4
Instructions	5

Appendix

Detail A: Exploded View	14
Detail B: Part Listing.....	15



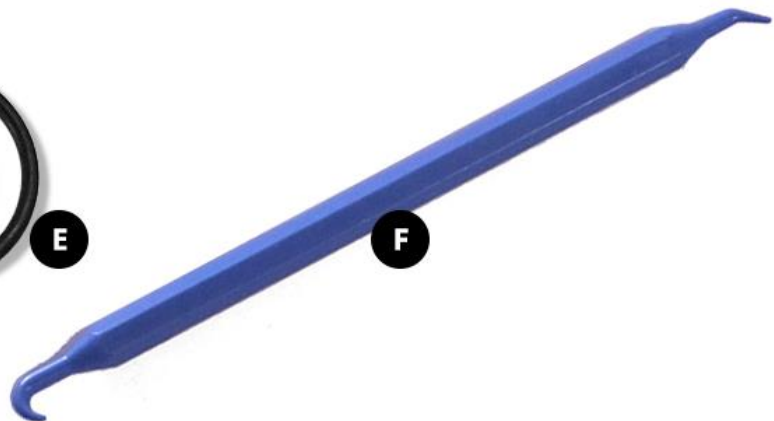

Maintenance Kit Components

55-200-2-25-01

Description	Quantity	Bison Part Number
<u>1.5" Standard Cylinder:</u>		
A) #6 x 1/4" Phil Pan S.M.S. 304 Stainless Steel	12	04-000-1-45-32
B) Check Valve	2	04-000-5-75-03
C) Piston Cup Seal	2	04-002-3-71-02
D) Internal Retaining Ring Stainless Steel	2	04-022-1-68-03
E) End Cap O-Ring	4	04-103-3-70-01
F) Seal Pick Tool	1	55-001-0-07-00

Before you begin

In the instructions there will be letter references such as “Seal Pick Tool (F)”. The letter refers to the identifier of the item listed in one of two locations: The **Contents Section of the Maintenance Kit** or in **Required Tools**. The contents section lists all items included in your Maintenance Kit.

There will also be item number references such as “Check Valve (Item 2)”. The item number refers to the assembly number of the item listed and can be found in both **Detail A: Assembly Views** and **Detail B: Part Listing**. All Maintenance Kit contents are included in these details except the items listed under Required Tools.

Please read and understand all instructions. If help is needed or you have questions regarding your product, you can call our Toll-Free Number 1-800-339-2601.

Required Tools:

- 1) One (1) Philips Screwdriver with a small tip
- 2) One (1) Pair of Adjustable Pliers or Pipe Strap Wrench
- 3) One (1) Pair of Internal Snap-Ring Pliers with .078 Tips
- 4) One (1) Bench Vice
- 5) One (1) pair of Safety Goggles
- 6) One (1) 8” Slender Shank Small Flat Blade screwdriver
- 7) One (1) can Extra Virgin Olive Oil
- 8) One (1) Seal Pick Tool (F) (**included**)

Instructions:

Step 1: Removing the Bottom End Cap

1) With your cylinder assembly outside your well, unscrew the Filter (Item 9) on the bottom of the Bottom End Cap (Item 8) using adjustable pliers, a pipe strap wrench or by hand. Set the Filter aside until time to reinstall. **(See Photo 1)**



Photo 1 – Bottom End Cap with Filter

2) Remove the Six (6) Philips Sheet Metal Screws (Item 1) holding the Bottom End Cap to the Cylinder Body (Item 6). With the screws removed, place the Bottom End Cap in a Bench Vice. **Verify that none of the Cylinder Body is in the vice to prevent damage.** Grasp the Cylinder Body and slowly pull while moving slightly side to side until the Bottom End Cap comes free from the end of the Cylinder Body. **(See Photo 2)**



Photo 2 – Bottom End Cap Removal

3) Remove the Bottom End Cap from the Bench Vice. Using the Seal Pick Tool (F) pry under the O-ring (Item 5) and work it off the Bottom End Cap and dispose of the used O-ring. (See Photo 3) Repeat the same process for the second O-ring.

4) **Put on Safety Goggles before attempting to remove the Internal Snap Ring (Item 4).** Insert the tips of the Internal Snap Ring Pliers into the two holes of the Internal Snap Ring. Squeeze the pliers together and pull outward removing the Internal Snap Ring that is holding in the Check Valve (Item 2) and dispose of the used ring. (See Photo 4)



Photo 3 – O-ring Removal



Photo 4 – Internal Snap Ring Removal

5) Turn the Bottom End Cap over and place on a hard surface leaving room for the check valve to be removed. Using the 8" flat head screwdriver or a rod roughly 1 ¼" in diameter, push the check valve out of the cavity and dispose of the used check valve.

6) Thoroughly clean the Bottom End Cap with fresh water paying close attention to the Check Valve cavity, Internal Snap Ring groove and O-ring grooves.

Step 2: Replacing Bottom End Cap O-Ring (E)

- 1) Place a new O-Ring over the Bottom End Cap. Using the Seal Pick Tool work the O-ring into the End Cap's O-ring Groove. Maneuver the O-ring so that it is seated inside the groove and not twisted. **Be careful not to stretch the O-ring.** (See Photo 5)



Photo 5 – O-Ring Placement

Step 3: Replacing Bottom End Cap Check Valve & Snap Ring

- 1) Coat the outer body of the Check Valve (B) with Extra Virgin Olive Oil. It is very important that the Check Valve is inserted into the Bottom End Cap with the correct orientation of flow. The end of the check valve with the O-ring should go in first (See Photo 6).



Photo 6 – Check Valve Orientation

2) Firmly push the Check Valve into the cavity until it is seated. The Check Valve should be completely past the Internal Snap Ring groove (See Photo 7). If any of the ring groove is covered by the Check Valve continue to press it into the cavity. It is not properly seated until the ring groove is completely exposed. Test the Check Valve by depressing the bottom and quickly releasing it. If the movement is clean and crisp the Check Valve is properly seated.



Photo 7 – Check Valve Placement

3) Put on Safety Goggles before attempting to install the Internal Snap Ring. Insert the tips of the Internal Snap Ring Pliers into the new Internal Snap Ring and squeeze the handle together. Insert the ring into its groove inside the cavity and release the handle. Verify that the Internal Snap Ring is completely seated inside the groove. Use a flathead screwdriver and push down on the snap ring. The snap ring should not freely spin when fully inside the groove. (Reference Photo 4)

Step 4: Replacing Top End Cap O-Ring

- 1) Remove the Six (6) Philips Sheet Metal Screws holding the Top End Cap (Item 7) to the Cylinder Body in the same manner as the Bottom End Cap. With the screws removed, place the Top End Cap in a Bench Vice. Verify that none of the Cylinder Body is in the vice to prevent damage. Grasp the Cylinder Body and slowly pull while moving slightly side to side until the Top End Cap comes free from the end of the Cylinder Body. (Reference Photo 2)
- 2) Remove the Top End Cap from the Bench Vice. Using the Seal Pick Tool pry under the O-ring and work it off the Top End Cap and dispose of the used O-ring. (Reference Photo 3) Repeat the same process for the second O-ring.

- 3) Thoroughly clean the Top End Cap with fresh water paying close attention to the O-ring grooves.
- 4) Place a new End Cap O-Ring over the Top End Cap. Using the Seal Pick Tool work the O-ring into the Top End Cap's O-ring Groove. Maneuver the O-ring so that it is seated inside the groove and not twisted. **Be careful not to stretch the O-ring.** (Reference Photo 5)
- 5) Set the Top End Cap aside until time to reinstall.

Step 5: Removing old Piston Cup Seals (C) and Check Valve (B)

- 1) Grasp the Piston Lift Rod and pull the Piston Assembly (Item 10) straight out of the Cylinder Body. (See Photo 8)

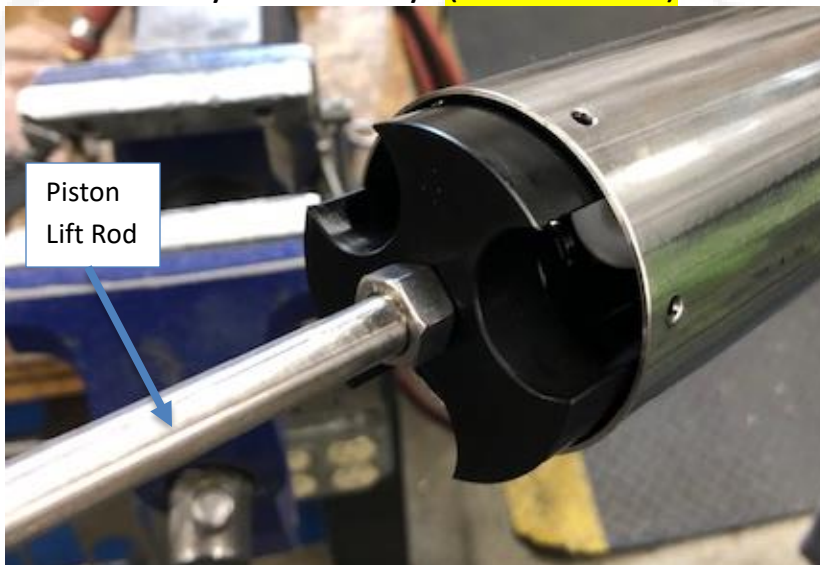

Photo 8 – Piston Assembly Removal

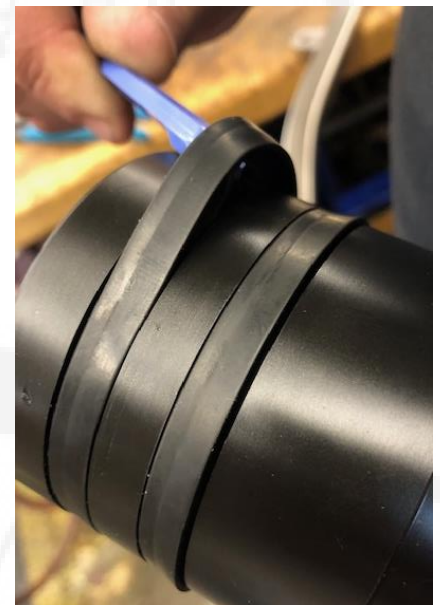

Photo 8.1 - Cup Seal Removal

- 2) Slide the tip of the O-Ring Pick Tool under the Piston Cup Seal (Item 3) and work it off the end of the piston (See Photo 8.1). Repeat the process for the second cup seal.
- 3) **Put on Safety Goggles before attempting to remove the Internal Snap Ring.** Using the Internal Snap Ring Pliers with .078 Tips, insert the tips into the two holes of the Internal Snap Ring. Squeeze the pliers together and pull outward removing the Internal Snap Ring that is holding the Piston Check Valve (Item 2) and dispose of the used ring. (Reference Photo 4)

- 4) Turn over the piston assembly and place the piston on a hard surface leaving room for the check valve to be removed. Using the 8" flat head screwdriver, push the Check Valve out of the cavity and dispose of the used Check Valve. **See Photo 8.2**
- 5) Thoroughly clean the Piston with fresh water paying close attention to the Check Valve cavity, Internal Snap Ring groove and Cup Seal grooves.



Photo 8.2 –Piston Check Valve Removal

Step 6: Replacing Piston Check Valve

- 1) Coat the outer body of the new Check Valve with Extra Virgin Olive Oil. It is very important that the Check Valve is inserted into the Piston with the correct orientation of flow. The end with the O-ring should be facing out **(See Photo 9)**. **Be sure to depress the four (4) tabs on the Check Valve before inserting into the**



Photo 9 – Piston Check Valve Orientation

- 2) **Piston Body. (See Photo 10)** Some tabs may break in this process. This will not affect the function or fit of the check valve.
- 2) Firmly push the Check Valve into the cavity until it is seated.



Depressed Tabs

The Check Valve should be completely past the Internal Snap Ring

groove. **Reference Photo 7**. If any of the ring groove is covered by the Check Valve continue to press it into the cavity. It is not properly seated until the ring groove is completely exposed. Test the Check Valve by depressing the bottom and quickly releasing it. If the movement is clean and crisp the Check Valve is properly seated.

- 3) **Put on Safety Goggles before attempting to install the Internal Snap Ring**. Insert the tips of the Internal Snap Ring Pliers into the new Snap Ring and squeeze the handle together. Insert the ring into its groove inside the cavity and release the handle. **Verify that the Internal Snap Ring is completely seated inside the groove**. Use a flathead screwdriver and push down on the snap ring. The snap ring should not freely spin when fully inside the groove. **(Reference Photo 4)**

Step 7: Replacing Piston Cup Seals

- 1) Place a new Cup Seal over the end of the Piston and work it into the Cup Seal groove. Make sure the Cup Seal Lips are facing towards the Piston Lift Rod **(See Photo 11)**. Repeat the process for the second Cup Seal.

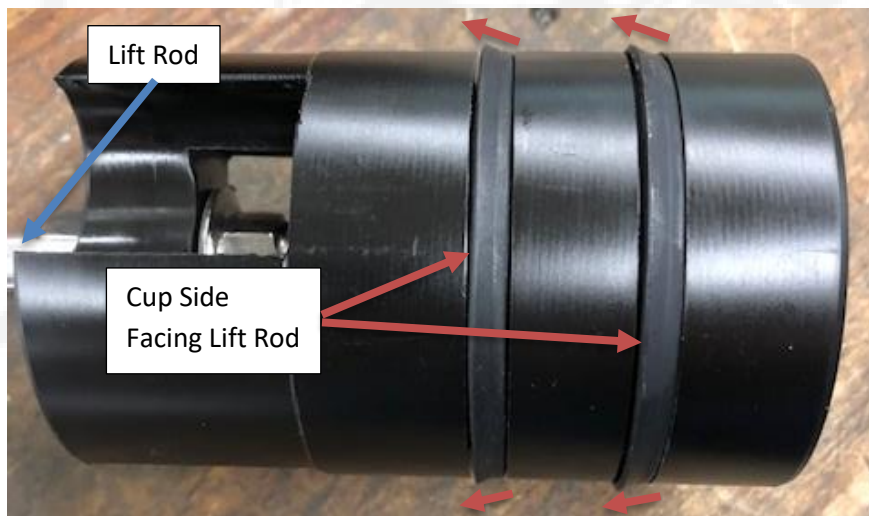

Photo 11 – Piston Cup Seal Orientation

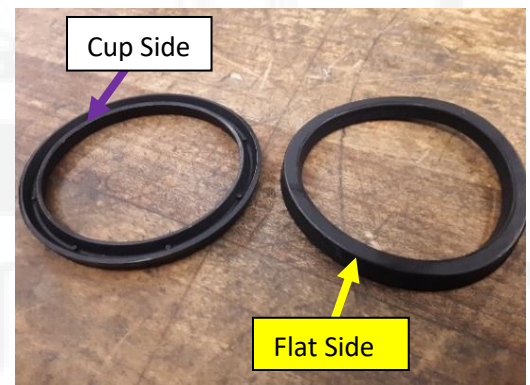

Photo 11.1 – Piston Cup Seal

Step 8: Reassembling the Cylinder

- 1) Clean the Cylinder Body with fresh water.
- 2) Insert the Bottom End Cap into the Cylinder Body and align the holes. Screw in the Six (6) Philips Sheet Metal Screws. (Reference Photo 2)
- 3) Insert the Filter and screw into the Bottom End Cap using the Adjustable Pliers, Pipe Strap Wrench or by hand. (Reference Photo 1) Do not overtighten.
- 4) Lightly Lubricate the inside of the Cylinder Body and the Piston Cup Seals with Extra Virgin Olive Oil.
- 5) Insert the Piston Assembly into the top of the Cylinder Body leaving 4-5 inches of the Lift Rod exposed. (Reference Photo 8)
- 6) Insert the Top End Cap into the Cylinder Body and align the holes. Screw in the Six (6) Philips Sheet Metal Screws.

Step 9: Test the Pump Cylinder

- 1) Grasp the Piston Lift Rod and pull up and down. Listen for the “Burp” of the check valves. As the Lift Rod is pulled upward you will hear the Bottom End Cap Check Valve Burping. When the Lift Rod is pushed downward you will hear the Piston Check Valve Burping.

*For Technical Help call our Toll-Free Number 1-800-339-2601

BISON PUMPS
The Power of Water in Your Hands



Appendix

BISON PUMPS
The Power of Water in Your Hands

Detail A: Exploded View

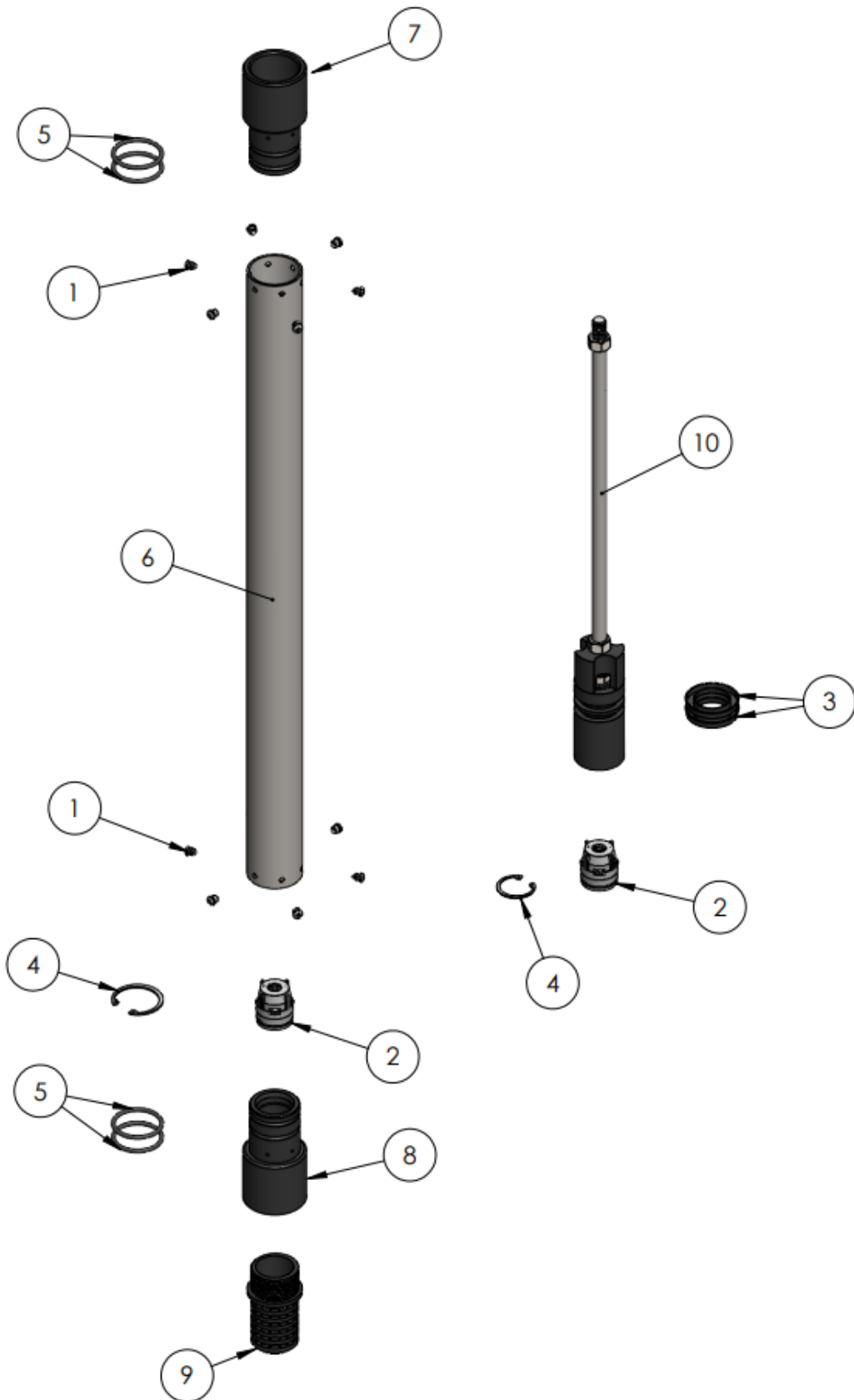

Detail B: Part Listing

Item No.	Part Number	Description	Quantity
1	04-000-1-45-32	Philips Sheet Metal Screws	12
2	04-000-5-75-04	Check Valve	2
3	04-002-3-71-02	Piston Cup Seal	2
4	04-022-1-68-03	Internal Snap Ring	2
5	04-103-3-70-01	O-ring	4
6	51-200-3-01-02	Cylinder Body	1
7	51-200-3-01-04	Top End Cap	1
8	51-200-3-01-04	Bottom End Cap	1
9	51-200-2-01-05	Filter	1
10	51-200-3-02-01	Piston Assembly	1



BISON PUMPS
The Power of Water in Your Hands