



Standard Deep Well Hand Pump Owner's Manual

Pump Head Revision Level J

Cylinder Revision Levels: 3"- E, 2.5"- B, 2"- D, 1.5"- D

Serial No. _____

BISON PUMPS
The Power of Water in Your Hands

Proudly Manufactured in Conway, Arkansas, UNITED STATES OF AMERICA.

Table of Contents

Product Specifications	4
Collage of Contents	6
Installation Options	7
Standard Pump Installation Instructions	8
Addendum A: Heavy Duty Pump Head and Handle Option.....	16
Addendum B: Pressurizing Kit Installation Instructions	17
Addendum C: Tamperproof Installation Instructions	19
Addendum D: Conduit El Installation Instructions.....	20
Addendum E: Reducer Bushing Kit Option	21
Additional Installation Tips	22

Appendix

Detail A: Standard Pump System Parts Breakdown.....	24
Detail B: Standard Installation with a Pressure Tank.....	25
Detail C: Weep Hole Location Diagram.....	26
Detail D: Pump Assembly Exploded View	27
Detail E: Pump Assembly Part Listing	28

Detail F: Standard Cylinder Assembly Exploded View 29

Detail G: Standard Cylinder Assembly Part Listing..... 30

Detail H: Pipe & Rod Assembly Exploded View..... 32

Detail I: Pipe & Rod Assembly Part Listing..... 33





Bison Deep Well Hand Pump

Owner's Manual

Product Specifications

Description: The Standard Deep Well Hand Pump is a Side-By-Side Deep Well Pump System that installs in the same well casing as your electric submersible pump system. It is recommended when there is sufficient space inside the well casing and the water from an electric submersible pump system exits underground.

Design and Construction

- Stainless steel construction of pump head, lift rod, handle and hardware
- Hand-polished for a professional shine finish
- Delivers approximately 20 oz. per stroke (with a 3" standard cylinder)
- Pumps from 250 foot depth
- Freeze proof
- No priming needed
- No routine maintenance
- Lifetime warranty

Options

- Heavy Duty Pump Head and Handle (for depths up to 300 feet)
- Pressurizing Kit (able to pressurize home water system)
- Tamperproof Well Pump Adapter with hardware
- Conduit El (to enclose electric submersible wiring)
- Reducer Bushing Kit (for connecting to 1" drop pipe)

Dimensions

Pump Head

- Overall height: 39"
- Inlet connection: 1 ¼" NPT male thread
- Spout connection: ¾" Garden Hose male thread
- Handle: 36"
- Weight: 25 pounds

Drop Pipe and Rod

- Overall Length: 8' standard (4' available)
- Drop Pipe Sizes: 1" or 1 ¼" NPT Schedule 120 PVC threaded
- Rod: 3/8" diameter 304 stainless steel
- Weight: Approximately 8 pounds per 8 foot section (1 ¼" drop pipe & rod)

Standard Cylinder

- Overall Length: 22.5" (24.25" with plastic screen installed)
- Diameter: 1.5", 2", 2.5" and 3" available
- Output & Weight: See table below

Cylinder Diameter	1.5"	2"	2.5"	3"
Output per stroke	4 oz.	8 oz.	12 oz.	20 oz.
Cylinder Weight	3 lbs.	3.5 lbs.	4.5 lbs.	6 lbs.

Contents

- (1) – 304 Stainless Steel Pump Head
- (1) – 304 Stainless Steel Bottom Plate Kit
- (1) – Deep Well 304 Stainless Steel Standard Cylinder with safety rope
- (1) – Schedule 120 PVC Drop Pipe and 3/8" Stainless Steel Rod (in 8' lengths sufficient to reach approximately 20' below your static water level)
- (1) – Brass Hose Bibb Cap
- (1) – Installation Paddle
- (1) – Rod Retrieval Tool
- (4) – Socket Set-Cup Point and Cup Point Cover
- (1) – Installation Manual

BISON PUMPS
The Power of Water in Your Hands



THE POWER OF WATER IN YOUR HANDS

Installation Options

Warning – You must comply with your local plumbing code. Contact a certified plumber if you have questions about proper plumbing codes in your area.

Before you begin the installation of your new pump, open the box and inspect the contents. Verify that you have received everything that you ordered. If there is anything that is missing or doesn't match, please call Bison Pumps immediately to correct the situation (1-800-339-2601).

Record your Deep Well Pump Serial Number on the front page of this manual.

Location – Before deciding on the location of your pump, you should consider whether you intend to use it to pressurize your home water system. If you do, then you should consider the location of your pressure tank drain valve or other access location (i.e., yard hydrant or outside faucet) in relation to the pump's location. Our Optional Pressurizing Kit (55-001-0-03-01) or Check Valve with pressure gauge (55-001-0-01-01) would have to be installed onto the spout of the pump and a hose ran from the pressurizing kit to the access location for your pump to pressurize the water system. Be certain that you have an accessible path from the pump spout to the water system access point and clearance for handle functionality. See **Addendum B and Detail B** for more information.

Read the instructions completely before beginning the installation process.

BISON PUMPS
The Power of Water in Your Hands

Standard Pump Installation Instructions

(Bison Pumps recommends that two people be involved for ease of installation.)

(Bison Pumps recommends installation from a licensed well driller/installer)

Step #1: Verify there is proper space for the hand pump and standard cylinder

Drop Pipe and Rod:

For the optimum ergonomic position, it is best to have approximately 12"-18" of casing above ground (See Detail A). During the installation, you will need a clean space to layout the drop pipe & rod and standard cylinder. When performing maintenance of the standard cylinder all the drop pipe & rod will have to be removed. Ensure there is sufficient room to accommodate this.

Standard Cylinder:

The Bison Pump standard cylinder that you purchased requires a certain amount of space inside the casing. Review your packing slip to verify the size of standard cylinder that you ordered. ***If your well casing already includes a submersible or jet pump, TURN OFF THE ELECTRICITY to the pump.*** Remove the existing well cover or seal and set it aside. Measure the space available in the casing for the standard cylinder to pass by. If it exceeds the diameter of your standard cylinder, then you are ready to proceed. However, if the available space is smaller than your standard cylinder then you either: A) Lift your submersible pump or deep well jet assembly and foot valve out of the well casing to allow the Bison Pump Standard Cylinder to pass by the Pitless Adapter or other obstructions in your well casing. Or B) Select a smaller Bison Pump standard cylinder that will pass through your available space.

Step #2: Installation items needed

Tools required: ½", 9/16" and 7/16" open end wrenches, pliers, vice grips, cordless or electric drill with 1/8" drill bit, 3/16" allen wrench, 1 1/8" bimetal hole saw (if using Bison side mount conduit el)

Supplies required: Measuring tape, gloves, potentially Teflon tape, a felt pen, Installation Paddle & Rod Retrieval Tool (both included with pump system), wire splicing kit

Note: If more than 14 lengths of drop pipe & rod will be installed, a mechanical means of lowering them into the well is recommended.

If you are installing the pump in a well casing specifically dedicated to a hand pump (well does not contain a submersible or jet pump) go to **STEP #4**. Otherwise proceed with **Step #3**.

Verify the electricity is off to the submersible or jet pump before beginning the installation of the Bison Hand Pump

Step #3: Wiring for the submersible or jet pump

Be sure to shut off power to the electric submersible pump. Locate and close the electric submersible supply line valve.

Bison Pumps offers two Conduit Pulling Elbows (Conduit El), one for top mount with wires coming out the top of the well pump adapter: **Top-Mount Electrical Conduit El (Bison Part # 55-200-1-09-01)** and one for side mount with wires coming out of the side of the casing: **Side-Mount Electrical Conduit El (Bison Part # 55-200-0-09-01)**. If you purchased either of these from Bison Pumps, follow the instructions in **Addendum D** for installation.

In both cases the wire is enclosed in conduit once outside the well casing. Disconnect the PVC conduit coming from the ground up to the existing well adapter. Loosen bolts on the existing well adapter and remove it. Now there should be access to the electric submersible pump wires inside the well casing. Secure the wires below the wire nuts and disconnect or cut wires.

Now is a good time to locate and mark the hole location if using the side mount conduit el. A normal ideal location is in the pump handle direction, slightly offset to the left or right. Ensure that the side mount conduit el and wires will not interfere with the pipes inside the well casing.

The Side Mount Conduit El can be installed at this time (**See Addendum D**). After installation, pass the electrical wires through the drilled hole in the side of the well casing and splice together inside the well casing. Reconnect the PVC conduit coming from the ground up to the well adapter. Continue with the installation of the Bison pump system.

See Step 12 for when to install and pass electrical wires through the Top Mount Conduit El.

Step #4: Unpack Standard Cylinder and Drop Pipe & Rod

Unpack the Bison pump system Standard Cylinder, Drop Pipe & Rod, Rod Retrieval Tool, and the Installation Paddle. **Verify that all items ordered were received by comparing the contents with the supplied packing slip.**

Standard Cylinder: The standard cylinder will be shipped inside the box with the pump head. Remove the standard cylinder from the box. **TAKE EXTRA CARE WHEN HANDLING THE STANDARD CYLINDER TO NOT DAMAGE THE BODY.** The standard cylinder will have a rope tied around it for safety. This rope will be used to secure the standard cylinder as it is lowered into the well. Remove the plastic plug from the end of the standard cylinder. Using the Rod Retrieval Tool (thread it onto the cylinder piston rod) pump the piston 3-4 times, listening for a 'burp'

sound. **If you do not hear a 'burp' sound, stop and call Bison Pumps before proceeding.** After checking for the 'burp', pull the rod out of the piston until approximately 8" of the rod are exposed. Remove the Rod Retrieval Tool and set the standard cylinder aside once completed. **DO NOT REMOVE THE ROPE.** See **Details F & G** for exploded views and part listings of the standard cylinder assembly.

Drop Pipe & Rod: Depending upon your order there could be multiple boxes of Drop Pipe & Rod. Open the box and remove a section of Drop Pipe & Rod. In the inner and outside end of each section there will be plastic plugs. When the time comes to use the Drop Pipe & Rod all plastic plugs must be removed first.

Each section is eight (8) feet long and has a bell on one end. The "bell end" goes "up" and will be used to hold the pipe system with the Installation Paddle. See **Details H & I** for exploded views and part listings of the drop pipe & rod assembly.

Weep hole: If you live in an area that experiences freezing temperatures you will need to add a weep hole to the PVC Drop Pipe below your frost line. First you will need to determine the depth of the frost line in your area. Add that figure, in inches, to the height of the casing above the ground. You now have the total depth needed to be at the frost line in your area. Add another 9" to this figure to ensure you are below the frost line.

Remove a drop pipe & rod section from the boxes. Remove the rod from the drop pipe. Starting at the bell end, measure the distance calculated from the bell end and mark with a felt pen.

Using a cordless or electric drill with a 1/8" drill bit, drill a hole in the side of the PVC drop pipe (note to only drill the hole in ONE side). Shake the PVC drop pipe to clear out any debris from drilling the hole.

Note: This section of drop pipe with the weep hole is normally attached to the pump head. See **Detail C for the Weep Hole Location Diagram.**

STEP #5: Tie the safety rope to a secure object

Using the safety rope that is tied to the standard cylinder, tie the other end of the safety rope to a secure object (i.e., the well casing temporarily). The safety rope will later be tied to the 1/4" eye bolt on the underside of the well pump adapter in **Step #13.**

STEP #6: Connect the Standard Cylinder to the first piece of Drop Pipe & Rod

Note: when you receive your rod the coupling nut will already be tightened securely.

One person should hold the standard cylinder (with the lift rod protruding about 8" outside the top cap) straight up and down. The second person will hold the Drop Pipe & Rod straight above the standard cylinder with the "bell end" **pointed up** (It is important to maintain a straight line between the cylinder lift rod and the pipe rod so that they can be screwed together). The person holding the standard cylinder will grasp the rod end with the Coupling Nut and screw it onto the Cylinder Lift Rod. The cylinder lift rod should butt against the pipe rod inside the coupling nut. Using $\frac{1}{2}$ " and $\frac{9}{16}$ " open end wrenches, tighten the locking nut on the Cylinder Lift Rod against the coupling nut. **Be sure to tighten the $\frac{3}{8}$ " stainless steel jam nuts on both sides of the rod coupling (using a $\frac{9}{16}$ " open end wrench).**

STEP #7: Attach first PVC drop pipe section

Screw the PVC male end of the first 8' section of drop pipe into the female thread in the head of the standard cylinder and hand tighten. **DO NOT OVERTIGHTEN THE PVC DROP PIPE.**

The Drop Pipe will come with Teflon tape on the threads. If something causes this supplied Teflon tape to be unusable you **must replace it with new Teflon tape. DO NOT USE PIPE DOPE**

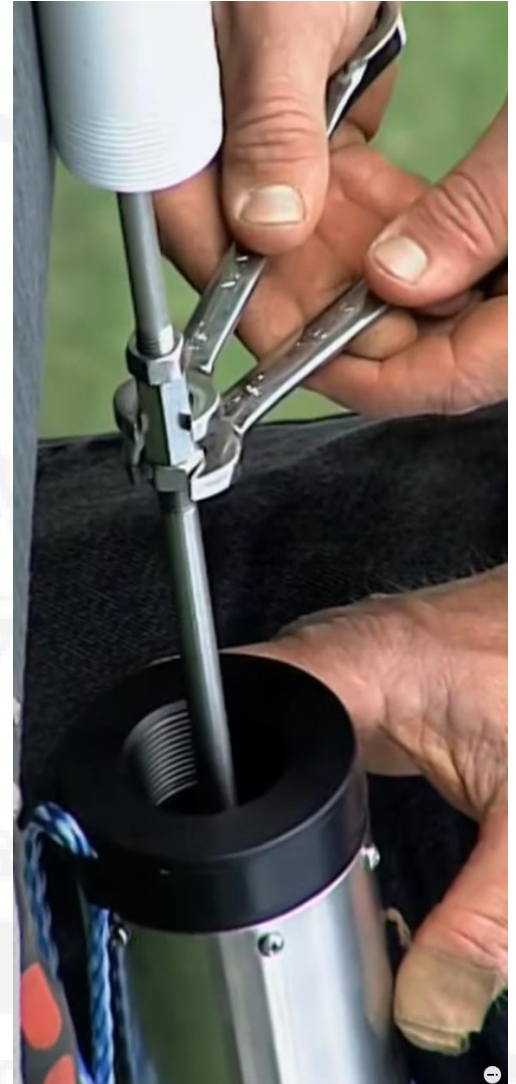

BISON PUMPS
The Power of Water in Your Hands

STEP #8: Insert the Installation Paddle

Retrieve the installation paddle. **Hold it so that the logo on the handle is facing up.** This paddle orientation will have the angled slot on top. This angle matches the drop pipe bell end. As the lengths of drop pipe and rod get heavier the paddle will try to cut into the PVC if the angle is on the bottom. One person now lowers the standard cylinder and the first 8' section of piping into the well. The second person slides the installation paddle, top side up, under the PVC bell end of the drop pipe and rests the paddle on top of the well casing. This will hold the drop pipe in place while you assemble the next rod and drop pipe.

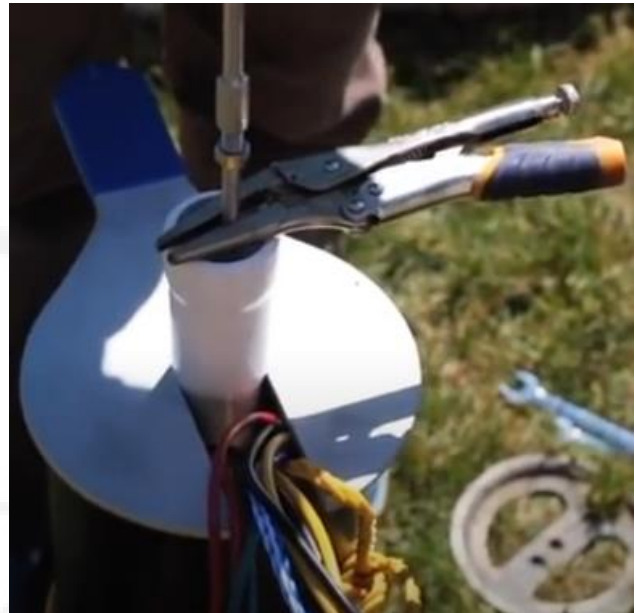

Verify that the paddle is sitting in the middle of the casing with the rope in the slot. Be careful that the rope and any wires remain in the slot through-out the installation process to prevent cutting of the rope or wires by the paddle.

STEP #9: Attach all sections of Drop Pipe & Rod

Attach the rod retrieval tool to the last section of rod and pull all the way up. Attach vice grips to the rod leaving about four inches of the rod above the vice grips. Slowly lower the rod until the vice grips are against the opening of the bell housing end of the PVC drop pipe. This will hold the rod up from the drop pipe to allow the next section to be attached.

Remove the next section of drop pipe & rod from the box. Remove all plastic covers. One person should hold the drop pipe & rod straight above the previous section. The other person will grasp the rod end with the Coupling Nut and screw it onto the rod. The bottom rod should butt against the pipe rod inside the coupling nut. Using $\frac{1}{2}$ " and $\frac{9}{16}$ " open end wrenches, tighten the locking nut on the rod against the coupling nut.

Continue to connect the $\frac{3}{8}$ " locking & coupling nuts and PVC Drop Pipe until you have lowered all of the drop pipe into the well. **DO NOT OVERTIGHTEN THE PVC DROP PIPE.**

Be certain that the section of drop pipe and rod attached to the pump head has the weep hole installed.

STEP #10: Unpack the Bison Pump Head

Remove the Bison pump head from the shipping box. It will have a plastic plug on the bottom water inlet; remove and discard this plug. Also remove the Brass Hose Bibb Cap (Detail D – Item 13) and set aside until needed later.

STEP #11: Prepare the handle for installation

Remove the handle shoulder bolt using a 3/16" Allen wrench and 1/2" open end wrench (See Detail D – Item 1). Lower the handle so that it lays against the pump body.

STEP #12: Attach the Bison Pump Head to the Drop Pipe & Rod

Note: Be sure that the last rod is sticking up out of the drop pipe and is held in place by the vice grips.

One person should hold the pump head over the well casing straight above the last drop pipe & rod. The other person will screw the 3/8" rod that is protruding from the last drop pipe into the bottom of the 1/2" lift rod protruding from the bottom of the pump head. This is best accomplished by spinning the lift rod into the 3/8" rod threads. Tighten these rods together using a 7/16" open end wrench on the flat cut into the lift rod and the vice grips holding the 3/8" rod. Thread the lock nut up against the lift rod and tighten using a 1/2" and 9/16" open ended wrench.

The person holding the pump head should raise the pump head until the eyelet on the end of the lift rod is against the gland nut on the top of the pump head. They should brace themselves for the weight of the drop pipe & rod.

The other person should quickly remove the vice grips once the other person is ready. Then slowly lower the pump head inlet pipe into the bell of the PVC drop pipe. The person holding the pump head should turn the pump head clockwise to screw the inlet pipe into the PVC drop pipe while the other person holds the PVC drop pipe. Hand tighten the inlet/PVC connection.

DO NOT OVERTIGHTEN.

Note: Orient the spout to the desired location before moving onto the next step.

If using the Top Mount Conduit El, now is the time to install it onto the well pump adapter (See Addendum D). Then, pass the electrical wires through the 3/4" NPT hole in the top of the well pump adapter and splice together inside the well casing. See Step 15 for connecting the PVC conduit coming from the ground to the top mount conduit el.

STEP #13: Secure the pump head to the well casing

Note: Go to **Addendum C** if you purchased the tamperproof option.

The safety rope needs to be tied to the pump head. First untie the rope from its secure location being sure to have a good hold on the rope so as not to drop it. Tie the end of the safety rope to the 1/4" eye bolt on the underside of the well pump adapter (See Detail A). Put all remaining rope inside the well casing.

Lift pump system, remove installation paddle, and slowly set the well pump adapter onto the casing, squarely and straightly; then evenly tighten the four (4) stainless steel nuts on top of the well pump adapter. These should be tightened in an alternating diagonal sequence where #1 is tightened first, then #3, then #2, then #4 and repeated until all four are tight. Screw the four (4) Socket Set-Cup Point all thread screws into the side of the well pump adapter to secure it to the casing. Check to make sure the pump head is square and straight on the well casing; making sure all the screws are tight. Place the four (4) plastic cup point covers over the Socket Set-Cup Point all thread screws of the well pump adapter.

STEP #14: Prepare the pump head handle for use

Reconnect the pump handle to the lift rod using the handle shoulder bolt with a 3/16" Allen wrench and 1/2" open end wrench (Detail D – Item 1). Do not over tighten the shoulder bolt as this will cause increased force to pump handle.

Note that the handle will likely be pulled down by the lift rod causing the handle to stick out straight. Lower the handle and attach the chain hook (Detail D – Item 8a) to the handle for it to remain in the lowered position.

Reattach the cap to the spout when not in use.

STEP #15: Electric Submersible Connections

After the Standard Pump Head is installed, connect the PVC conduit coming from the ground up to the top mount conduit el. If using the side mount conduit el, the PVC conduit should already be connected. Open the supply line valve that was closed at the beginning of installation. Turn power back on to the electric submersible pump and test for leaks and operation of the electric submersible line.

STEP #16: Using your Bison deep well pump for the first time

First remove the cap on the spout. Then, while depressing the handle with one hand, remove the chain hook with the other hand. Slowly begin to pump the handle. It could take several strokes depending on the depth of your well to initially prime the pump. Once primed, 2-3 strokes should produce water out of the spout.

If water comes out of the top of the pump, the gland nut (**Detail D – Item 17**) is likely too loose. Tighten the gland nut by hand in $\frac{1}{4}$ turn increments and try pumping again. Repeat this process until water ceases to flow out of the gland nut. **Do not overtighten** as this may cause difficulty in pumping your hand pump or damage to your lift rod.

Pump the handle on your Bison Deep Well Hand Pump and enjoy a cold glass of water directly from your well!

If you are currently treating the water in your home, remember that the water you pump directly from your well is untreated water. Bison Pumps recommends that you have your water tested to be sure that it is good quality potable drinking water.



BISON PUMPS
The Power of Water in Your Hands

Addendum A: Heavy Duty Pump Head and Handle Option

*Bison Pumps offers a Heavy Duty Pump Head and Handle Option designed for wells with a static water level greater than 250 feet or in high usage applications. It can be added to any of the deep well pump systems but must be ordered when the pump system is ordered.

The Heavy Duty Pump Head and Handle Option includes:

- Brass bushings in the handle linkage system
- A solid stainless steel link
- A solid stainless steel ear
- A stainless steel reducer tube for added support
- Two handle options for pumping at either greater depths or considerably higher rates of usage.

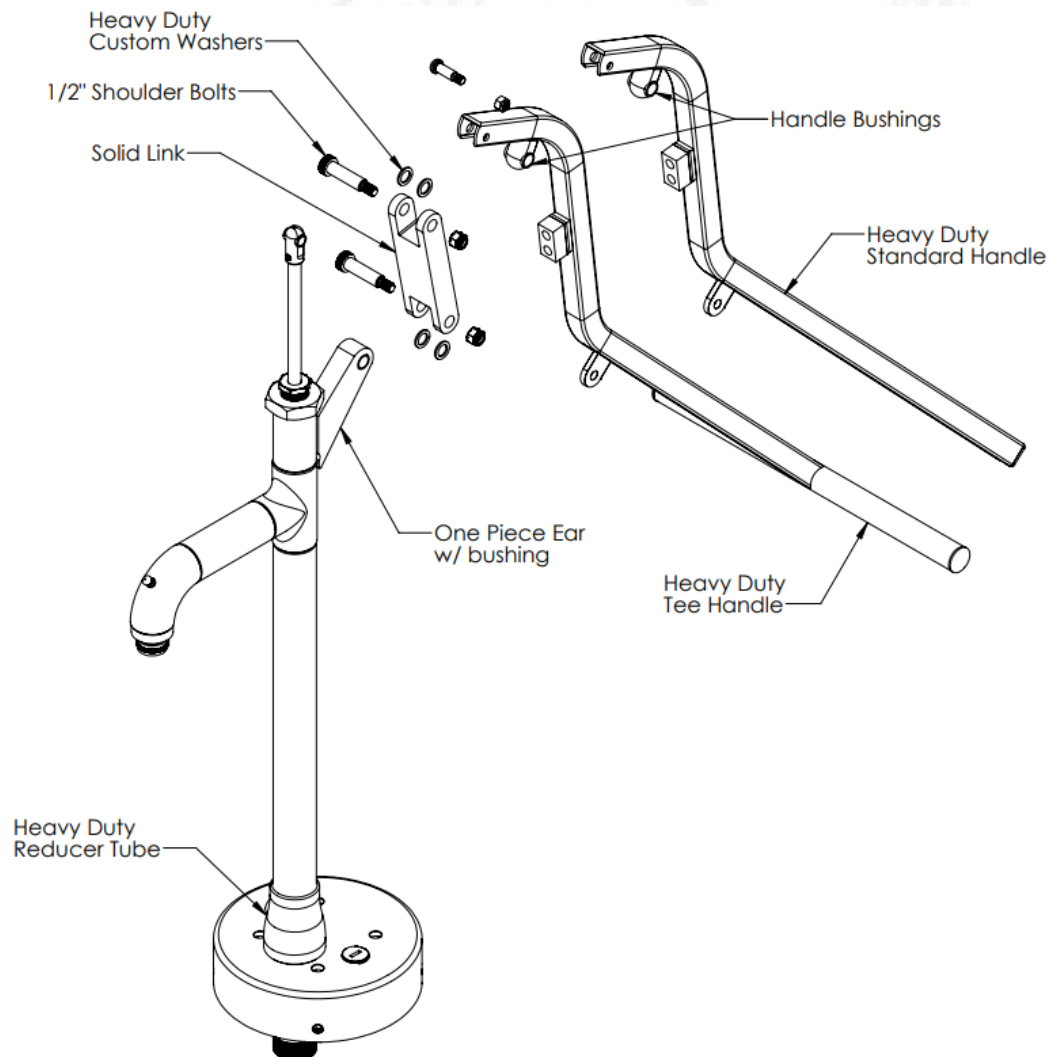

Addendum B: Pressurizing Kit Installation Instructions

*Bison Pumps offers a Pressurizing Kit consisting of a Lead-Free Brass Check Valve, a 100 PSI Pressure Gauge, a Bleed-off Valve, and a 10' Potable High Pressure Water Hose. See "Installation Options" on page 7 for ordering information.

1. **Turn OFF** the power to the electric pump - even if the power source is out. If you are pressurizing a system that normally uses an electric water pump, you will need to turn off the power to the pump before pressurizing with the hand pump. If the power is restored and the electric pump begins operating, damage or flooding through the pump could occur. Therefore, **TURN OFF POWER TO THE ELECTRIC PUMP**.
2. Close off the water source to the pressure tank from an electric pump. When pressurizing begins, the pump will draw from the water source. Water system access by electric pumps must be closed so that water is only accessible by the hand pump.
3. Connect the hand pump to the pressure tank. To pressurize your water system, connect the Check Valve (to prevent water backflow), Pressure Gauge (to know when the pressure tank is full), Bleed-off Valve (to safely relieve pressure) and a Potable High Pressure Water Hose (to transfer the water) to the spout of the hand pump. Connect the hose to the hydrant or another line feeding the pressure tank. (See Detail B)

Bison Pumps recommends using our Pressurizing Kit which contains all the required components. After the Pressurizing Kit is installed, open the drain valve on the pressure tank. **DO NOT DISCONNECT THE HOSE FROM THE CHECK VALVE OR THE CHECK VALVE FROM THE SPOUT WHILE THE PRESSURE TANK DRAIN VALVE IS OPEN.** Doing so will cause all water to flow out of the pressure tank.

4. Determine the amount of pressure that your pressure tank requires to be full. For most pressure tanks this is 40 to 60 PSI. The pressure inside your pump will be higher than under normal operating conditions. The pump's Gland Nut (Detail D – Item 17) must be adjusted to prevent leakage at the point where the Lift Rod exits the Gland Nut.

To adjust the Gland Nut for pressurization, begin pumping water into the pressure tank. If water leaks during pressurization, tighten the gland nut in ¼ turn increments until leaking stops. Continue pumping while watching the Pressure Gauge until the desired pressure is reached. **Do not over tighten** the gland nut as it could cause the pumping action to be more difficult or cause damage. Close the pressure tank drain valve to close off water access from the hand pump.

The hose is under pressure from the pressure tank drain valve to the Check Valve at the pump spout. Before removing the hose, slowly open the bleed valve on the pressurizing system. Be aware that there will be water spillage at this point. Prepare the area for excess water by having a bucket available to catch the water from the bleed-off valve and hose. Once the immediate pressure is released, then the hose can be detached from the pump and/or pressure tank.

5. Use your water system. With the pressure tank full, you can use any water fixture in your home. Be aware that you only have the amount of water that can be held in the tank available. Therefore, you should conserve the amount of water used to minimize the need to refill the tank by pressurization. When the tank pressure is too low for normal usage, you will need to repeat the pressurizing process.
6. To return to use of electric pump reset the water flow valves to accept water only from the electric pump. Turn the power on to the electric pump to allow it to begin normal operations.
7. To return the hand pump to normal operating condition: Loosen the gland nut until water leaks during normal pumping action. Next hand-tighten the gland nut in $\frac{1}{4}$ turn increments until leaking stops. This will be the ideal setting for the gland nut and ease of pumping operation. It is not necessary to use a wrench to tighten the gland nut. **Do not over tighten** as it could cause the pumping action to be more difficult or cause damage.



BISON PUMPS
The Power of Water in Your Hands

Addendum C: Tamperproof Installation Instructions



1. Place the well pump adapter together with the pump head on the well casing in the desired orientation and make sure it is level.
2. Screw in the truss head screws (Item 2) into the well pump adapter countersunk holes (Item 4) until they bottom out against the sides of the casing, which should score the casing and leave a mark showing the hole drilling locations. Loosen and remove the truss head screws (Item 2). Raise the pump head and support it on the installation paddle.
3. Center punch the two marks left on the well casing with a 7/32" drill bit. Then use a 5/8" drill bit to drill the two holes through each side completely. **It is important that these holes are drilled straight, not on an angle.** Apply a small amount of silicone to the rim of the white plastic boots (Item 1), and then insert into the 5/8" holes. Push in tightly to seat.
4. Reinstall the pump head and pump adapter back on the well casing, being careful not to pull the white boots out of the casing. Align the two drilled holes in the well casing with the countersunk holes (Item 4) on the pump head and pump adapter.
5. Install the truss head screws (Item 2) into the well pump adapter countersunk holes (Item 4) and tighten using the truss bit tool driver (Item 3) that is provided. **Do not force or overtighten the screws or the driver tool. If excess force is necessary, recheck the drilled holes and ream if necessary. Then try to install the screws again. They should screw in easily.**
6. Tighten the remaining nuts and lock bolts of the well pump adapter as per the installation instructions.

Addendum D: Conduit EI Installation Instructions

Verify the electricity is off to the submersible or jet pump before beginning

See the Conduit EI Installation video online for additional instructions.

Top-Mount Conduit EI

- a) **With the power OFF**, disconnect the wires coming out of the top of the well from the power source. Leave enough wire to pass through about 2 feet of conduit. Be sure to secure the wire to prevent it from falling into the well casing.
- b) The **Top-Mount Conduit EI** will ship fully assembled. Disconnect the male threaded adapter on the end of the assembly and thread it into the $\frac{3}{4}$ " NPT hole on the top of the well pump adapter until hand tight. This will take the place of the plastic electrical plug (Detail D – Item 9) in the well pump adapter.
- c) Insert the rest of the conduit assembly into the open end of the adapter as it was shipped.
- d) Pass the wire from outside the casing through the Conduit EI to the inside of the casing where you can re-connect the wires to the electric submersible pump.
Note: It may be easier to pass wires through the Conduit EI by removing the cover on the Conduit EI. Be sure to reattach the cover after the wires have been passed through.

Side-Mount Conduit EI

- a) **With the power OFF**, disconnect the wires inside of the well from the power source. Be sure to secure the wire to prevent it from falling into the well casing.
- b) Using a bi-metal hole saw, drill a 1 1/8" hole through the side of the well casing at least 6" below the top of the casing (note that the sides of the well pump adapter will cover the first 2" of casing).
- c) Remove the **Side-Mount Electrical Conduit EI** from the box. Remove the plastic nut, plastic Inner Block, and gasket leaving the plastic Outer Block intact. From outside the casing, insert the plastic threaded nipple through the 1 1/8" hole in the side of the casing. On the inside of the casing, slide the gasket over the plastic threaded nipple first, then the plastic Inner Block (be sure that it is oriented with the curved side facing the inside of the casing). Then secure it with the plastic nut. **Do not overtighten the plastic nut.**
- d) Pass the wire from outside the casing through the Conduit EI to the inside of the casing where you can re-connect the wires to the electric submersible pump.
Note: It may be easier to pass wires through the Conduit EI by removing the cover on the Conduit EI. Be sure to reattach the cover after the wires have been passed through.

Addendum E: Reducer Bushing Kit Option

*Bison Pumps offers a 1 ¼" to 1" NPT Reducer Bushing Kit Option designed for connecting to 1" NPT drop pipe instead of the standard 1 ¼" NPT. It can be added to any of the deep well pump systems and even existing systems. All components are made of stainless steel and come fully assembled to the pump head if ordered with the pump.

The 1 ¼" to 1" NPT Reducer Bushing Kit Option includes:

- A reducer bushing (1 ¼" to 1")
- A lift rod extension (to make up the length of the reducer bushing)
- A 3/8"-16 hex nut (to secure the lift rod extension to the lift rod)

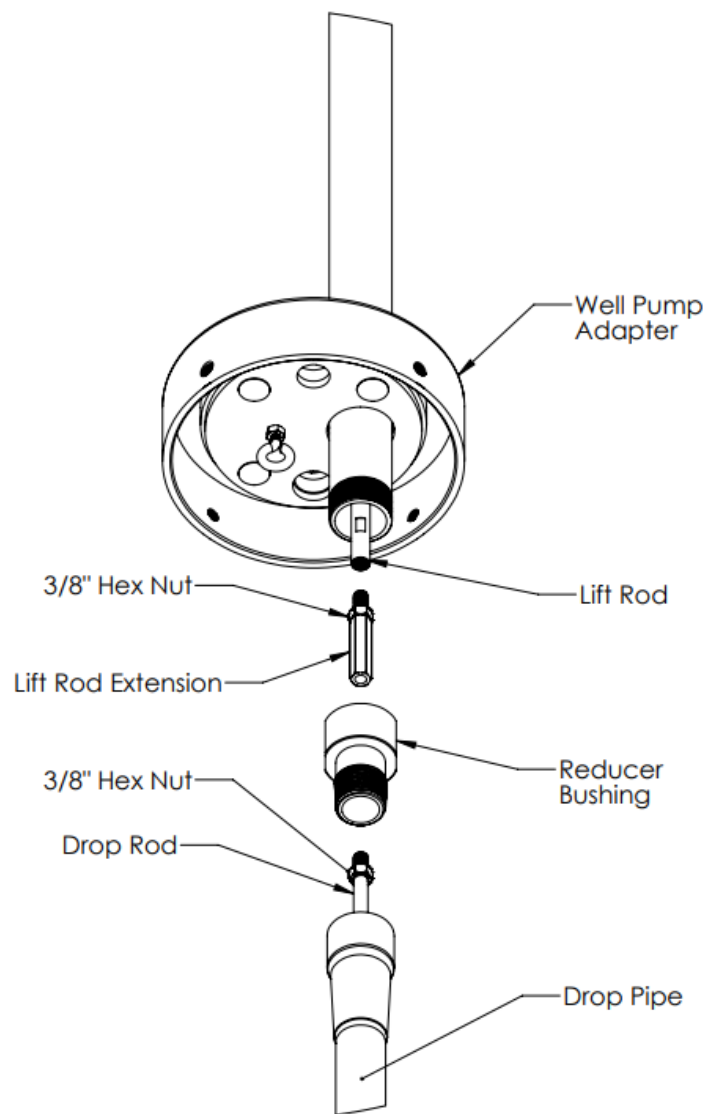

Additional Installation Tips

1. **Be sure to check local plumbing codes in your area to verify your installation meets all code requirements.**
2. If you live in an area that experiences freezing temperatures, be sure to drill a 1/8" hole below your frost line in the PVC drop pipe. See **Step #4 – Weep Hole & Detail C** for more information.
3. On the top of the pump body is a gland nut which the lift rod slides through when pumping your hand pump. ***This nut should be hand tight.*** If there is leaking through this nut when pressurizing a vessel, then tighten this gland nut in quarter turn increments until leaking stops. **Do not overtighten** as this may cause difficulty in pumping your hand pump or damage to your lift rod.

If the gland nut squeaks apply a small amount of Extra Virgin Olive Oil. This is used for lubricating the pump internally. Do not use petroleum products to lubricate the pump.

4. You will notice a handle locking loop is attached to your pump handle along with a stainless-steel chain and hook. If you choose, you can use either a paddle lock or a cable lock to secure the handle to the pump when not in use. Locking the handle is optional.
5. You will also notice that a brass hose bibb cap is shipped with the pump head. This cap can be tightened to the hose bibb to keep insects out when the pump is not in use. **Caution: In the winter months, be sure to let the pump drain back completely before securing the brass cap. You may not want to use the cap during the winter.**
6. If you experience any deficiencies or malfunction of your Deep Well Hand Pump, please contact Bison Pumps for assistance and answers to your specific questions or concerns.
7. Thank you for investing in a Bison Deep Well Hand Pump.

If you have any questions, please call 1-800-339-2601.



Appendix

BISON PUMPS
The Power of Water in Your Hands

Detail A: Standard Pump System Parts Breakdown

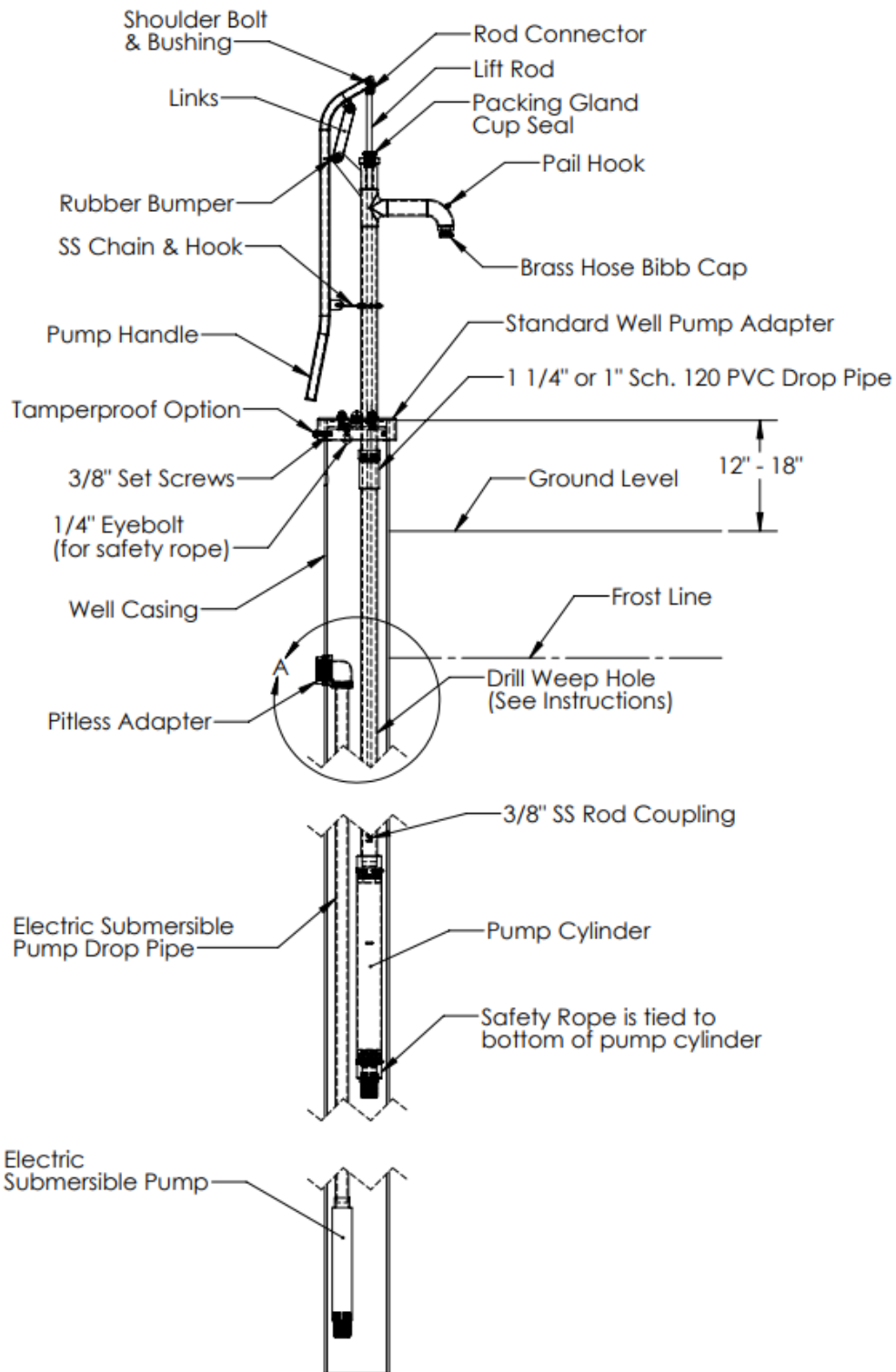

NOT TO SCALE

FOR ILLUSTRATION PURPOSE ONLY

Detail B: Standard Installation with a Pressure Tank

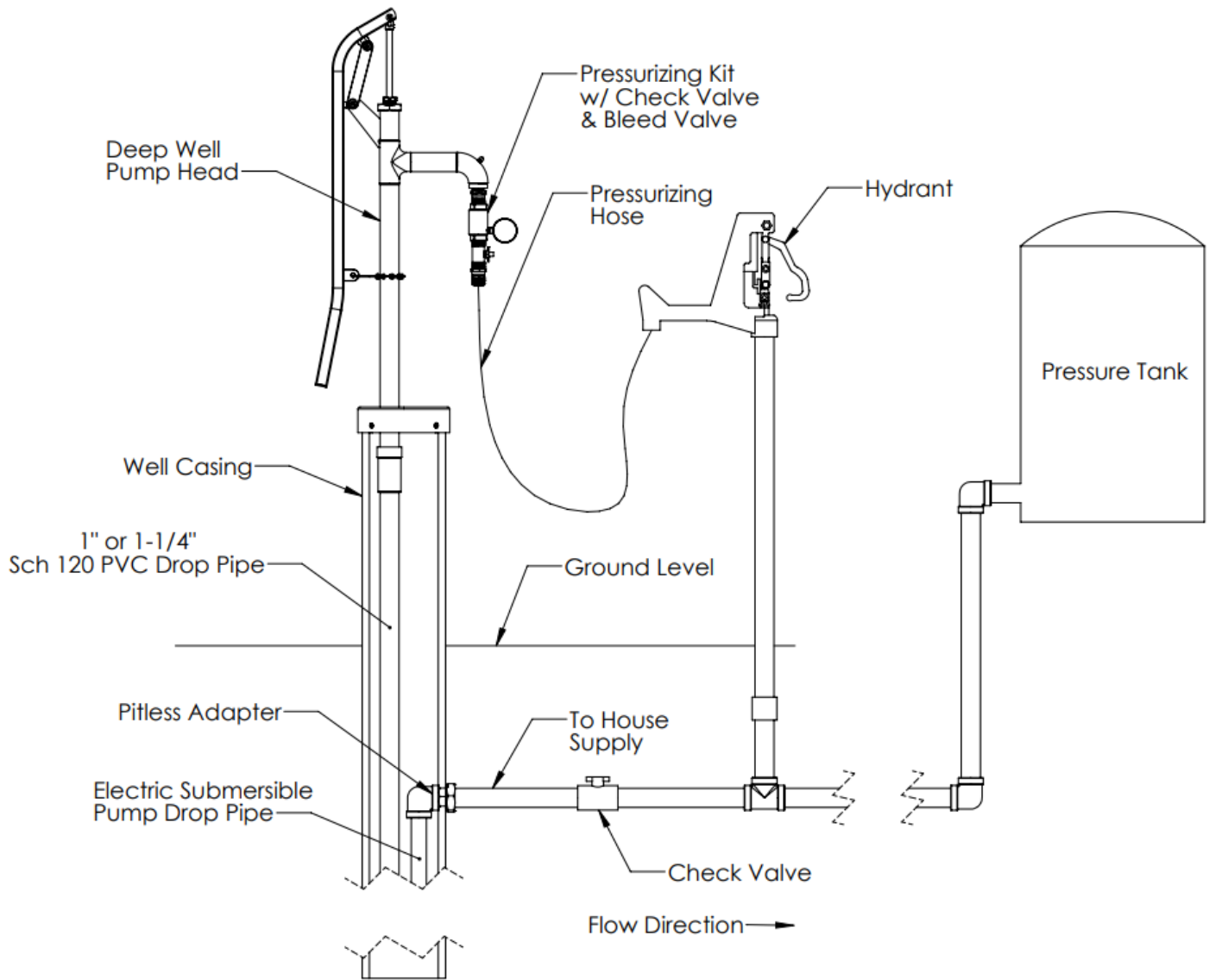

NOT TO SCALE

FOR ILLUSTRATION PURPOSE ONLY

Detail C: Weep Hole Location Diagram

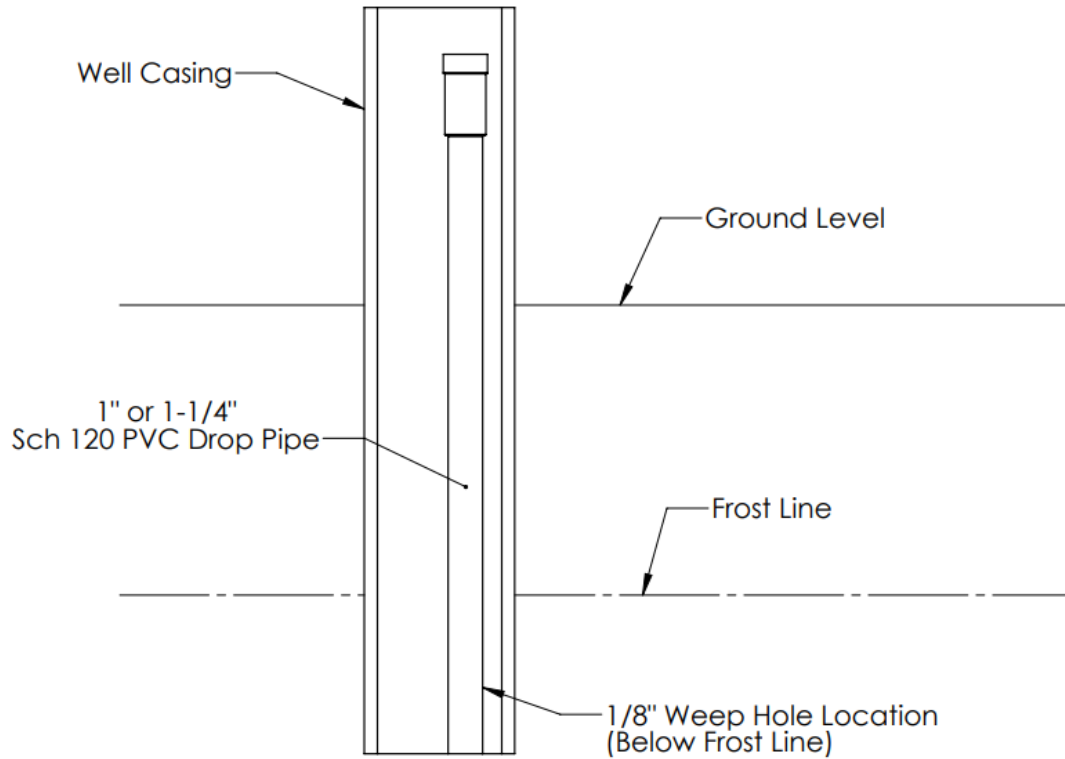

NOT TO SCALE

FOR ILLUSTRATION PURPOSE ONLY

Note: Depending on Well Casing height, and the frost line depth, it is possible for the weep hole location to be on the 2nd section of drop pipe instead of the 1st (the drop pipe connected to the pump head). Be sure to add the well casing height to the frost line depth to ensure the weep hole location is below the frost line.

The Power of Water in Your Hands

Detail D: Pump Assembly Exploded View

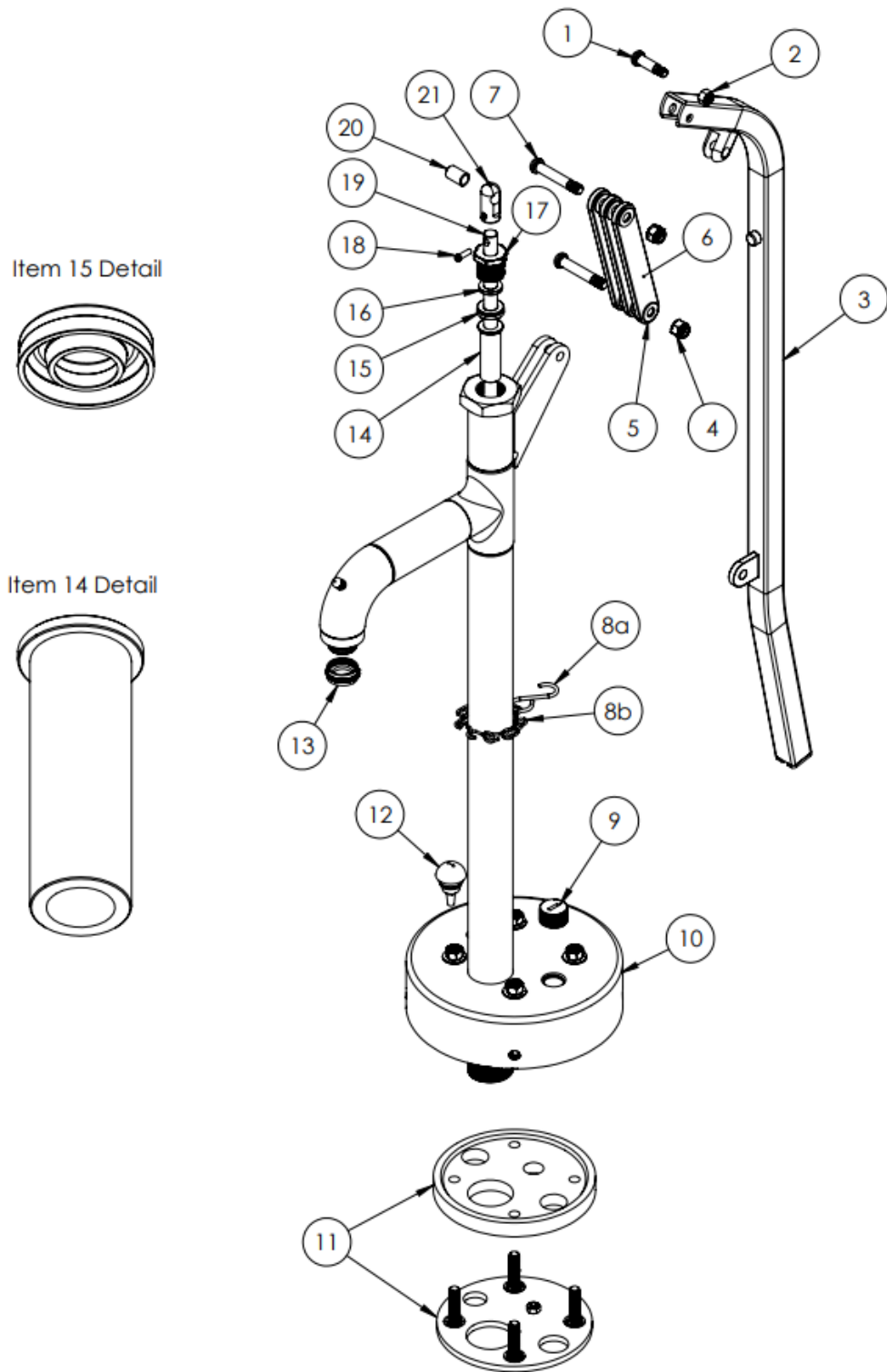

Detail E: Pump Assembly Part Listing

Item	Part Number	Description	Quantity
1	50-001-0-03-06	Handle Shoulder Bolt	1
2	04-000-1-50-19	Handle Hex Lock Nut	1
3	50-200-0-03-01	Handle	1
4	04-000-1-50-20	Link Hex Lock Nut	2
5	04-000-5-40-01	Link Washer	12
6	50-001-0-03-03	Link	3
7	50-001-9-03-10	Link Shoulder Bolt	2
8a	50-200-0-13-00	Chain Hook	1
8b	50-200-0-14-00	Handle Chain	1
9	50-200-0-10-02	Electrical Plug	1
10	---	Pump Body	1
11	---	Bottom Plate Kit	1
12	50-200-0-11-01	Vent Plug Assembly	1
13	55-001-0-06-00	Brass Hose Bibb Cap	1
14	50-208-0-08-05	Bottom Bushing	1
15	04-001-3-71-01	Packing Gland Cup Seal	1
16	04-000-5-40-02	Packing Gland Backing Washer	1
17	50-200-0-07-00	Gland Nut	1
18	50-001-0-04-05	Rod Connector Screw	1
19	50-200-0-04-03	Lift Rod	1
20	05-001-6-04-01	Bushing	1
21	50-001-0-04-04	Rod Connector	1

Detail F: Standard Cylinder Assembly Exploded View

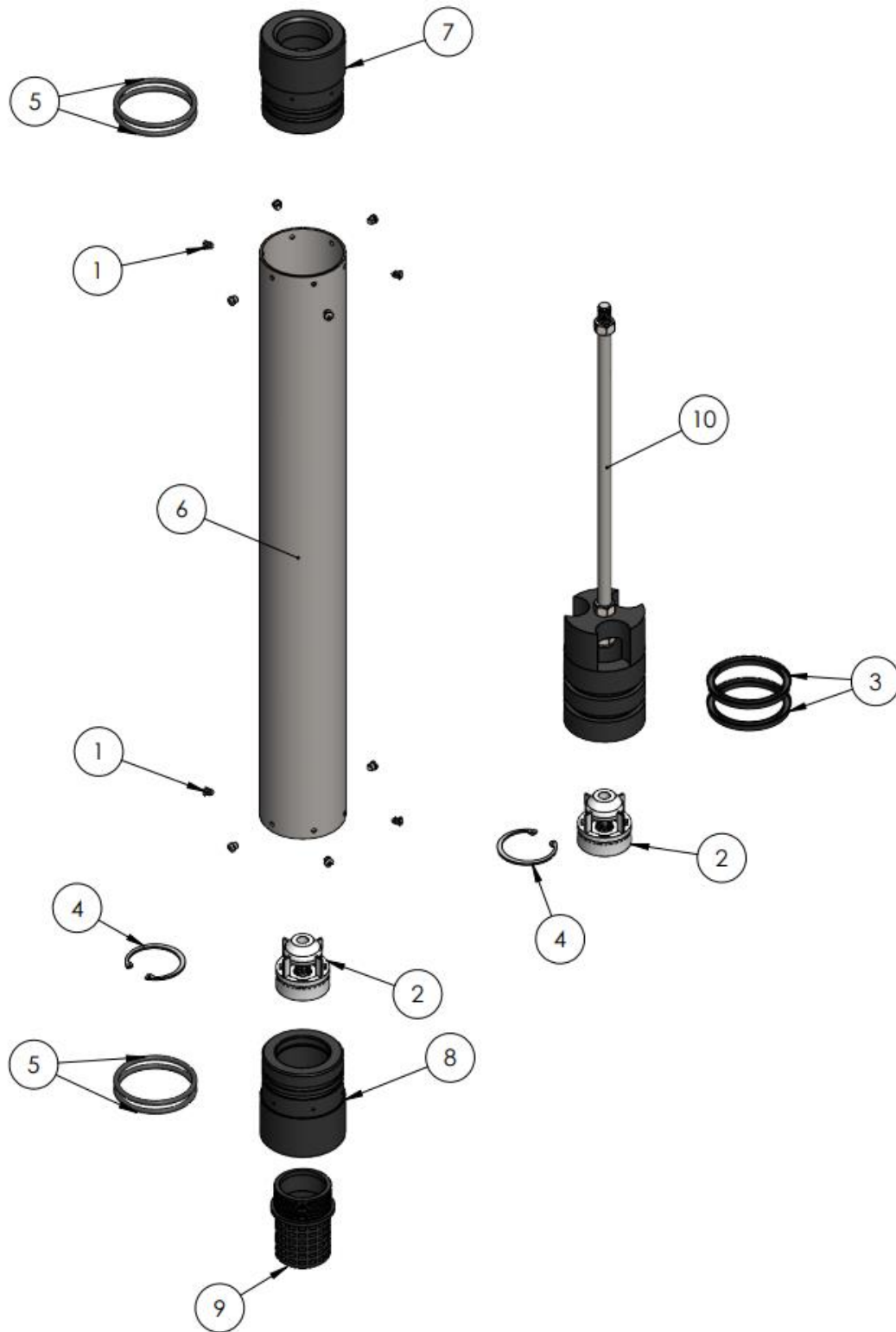

Detail G: Standard Cylinder Assembly Part Listing

3" Cylinder:

Item No.	Part Number	Description	Quantity
1	04-000-1-45-17	Philips Sheet Metal Screws	12
2	04-000-5-75-02	Check Valve	2
3	04-002-3-71-05	Piston Cup Seal	2
4	04-022-1-68-05	Internal Snap Ring	2
5	04-139-3-70-03	O-ring	4
6	51-200-0-01-02	Cylinder Body	1
7	51-200-0-01-03	Top End Cap	1
8	51-200-0-01-04	Bottom End Cap	1
9	51-200-0-01-05	Filter	1
10	51-200-0-02-01	Piston Assembly	1

2.5" Cylinder:

Item No.	Part Number	Description	Quantity
1	04-000-1-45-22	Philips Sheet Metal Screws	12
2	04-000-5-75-02	Check Valve	2
3	04-002-3-71-04	Piston Cup Seal	2
4	04-022-1-68-05	Internal Snap Ring	2
5	04-139-3-70-01	O-ring	4
6	51-200-1-01-02	Cylinder Body	1
7	51-200-1-01-03	Top End Cap	1
8	51-200-1-01-04	Bottom End Cap	1
9	51-200-0-01-05	Filter	1
10	51-200-1-02-01	Piston Assembly	1

2" Cylinder:

Item No.	Part Number	Description	Quantity
1	04-000-1-45-22	Philips Sheet Metal Screws	12
2	04-000-5-75-01	Check Valve	2
3	04-002-3-71-03	Piston Cup Seal	2
4	04-022-1-68-01	Internal Snap Ring	2
5	04-103-3-70-02	O-ring	4
6	51-200-2-01-02	Cylinder Body	1
7	51-200-2-01-03	Top End Cap	1
8	51-200-2-01-04	Bottom End Cap	1
9	51-200-0-01-05	Filter	1
10	51-200-2-02-01	Piston Assembly	1

1.5" Cylinder:

Item No.	Part Number	Description	Quantity
1	04-000-1-45-32	Philips Sheet Metal Screws	12
2	04-000-5-75-04	Check Valve	2
3	04-002-3-71-02	Piston Cup Seal	2
4	04-022-1-68-03	Internal Snap Ring	2
5	04-103-3-70-01	O-ring	4
6	51-200-3-01-02	Cylinder Body	1
7	51-200-3-01-04	Top End Cap	1
8	51-200-3-01-04	Bottom End Cap	1
9	51-200-2-01-05	Filter	1
10	51-200-3-02-01	Piston Assembly	1

Detail H: Pipe & Rod Assembly Exploded View

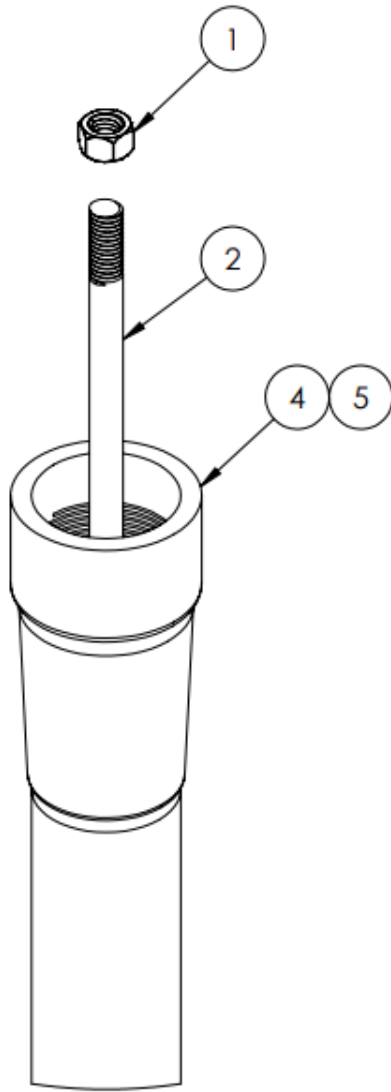

"Bell End"

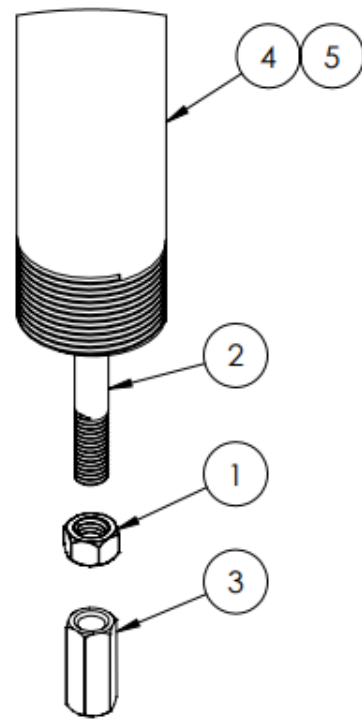

"Male End"

Detail I: Pipe & Rod Assembly Part Listing

Item No.	Part Number	Description	Quantity
1	04-000-1-50-22	Hex Nut	2
2	51-200-0-04-02	Drop Rod	1
3	51-200-0-04-03	Coupling Nut	1
4	51-200-0-05-00	1 ¼" Drop Pipe (Standard)	1
5	51-200-0-06-00	1" Drop Pipe (Optional)	1



BISON PUMPS
The Power of Water in Your Hands